

XTS

Dimensioni d'ingombro

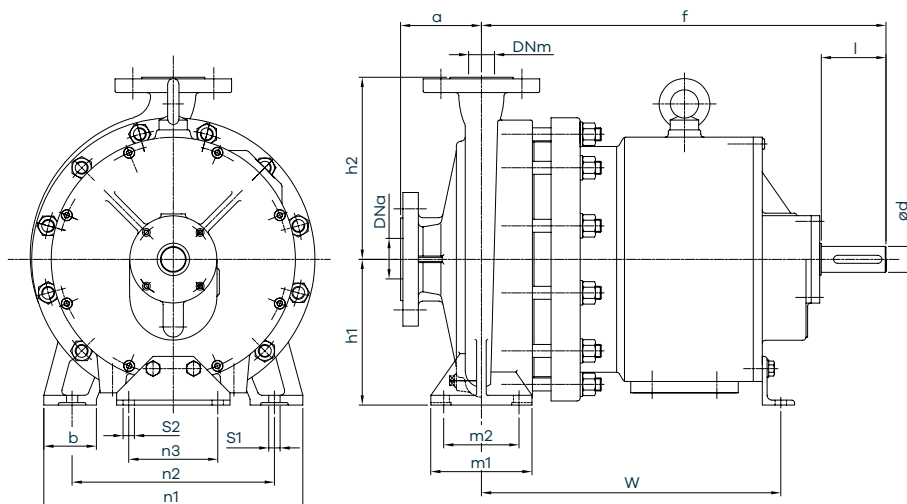

Dimensioni pompa

Modello	XTS 50-32-160	XTS 50-32-200	XTS 80-50-160	XTS 80-50-200
DNa	50	50	80	80
	UNI EN 1092-1 PN 16RF asolata ANSI 150			
DNm	32	32	50	50
	UNI EN 1092-1 PN 16RF asolata ANSI 150			
a (mm)	80	80	100	100
b (mm)	50	50	50	50
ød (mm)	24	24	24	24
*f (mm)	385	385	385	385
h1 (mm)	132	160	160	160
h2 (mm)	160	180	180	200
l (mm)	50	50	50	50
m1 (mm)	100	100	100	100
m2 (mm)	70	70	70	70
n1 (mm)	240	240	265	265
n2 (mm)	190	190	212	212
n3 (mm)	110	110	110	110
S1 (mm)	14	14	14	14
S2 (mm)	14	14	14	14
w (mm)	285	285	285	285
Peso pompa (senza motore)	55	90	60	90

*f la lunghezza 385 diventa 400 con anello paraolio contactless

XTS-B

Dimensioni d'ingombro

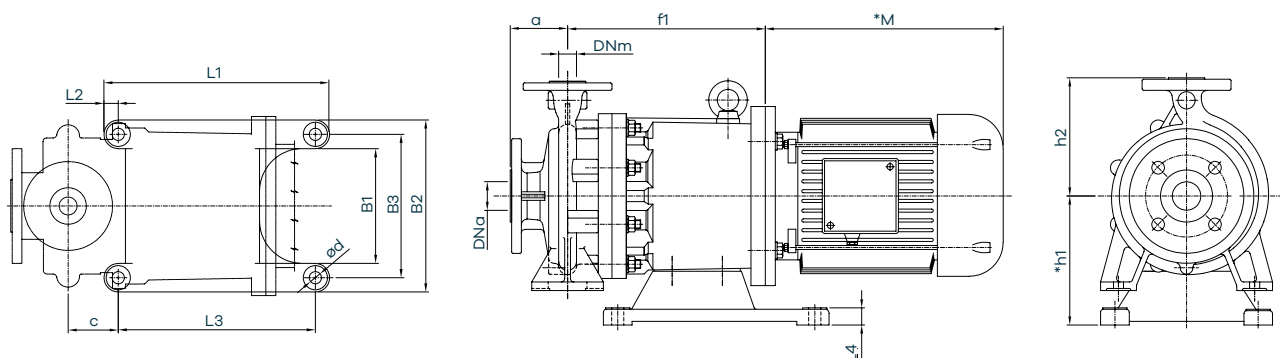

Dimensioni pompa

Modello	XTS-B 50-32-160	XTS-B 50-32-200	XTS-B 80-50-160	XTS-B 80-50-200
DNa	50	50	80	80
	UNI EN 1092-1 PN 16RF asolata ANSI 150			
DNm	32	32	50	50
	UNI EN 1092-1 PN 16RF asolata ANSI 150			
a (mm)	80	80	100	100
B1 (mm)	140	140	140	140
B2 (mm)	240	240	240	240
B3 (mm)	200	200	200	200
c (mm)	70	70	70	70
*h1 (mm)	180	180	180	180
h2 (mm)	160	180	180	200
L2 (mm)	20	20	20	20
Peso pompa (senza motore)	55	90	60	90

Dimensioni basamento

Dimensioni motore	Forma motore	Ød (mm)	L1 (mm)	L3 (mm)	L4 (mm)	f1 (mm)
80-90	B14	17	315	275	24	266
100-112	B5	17	315	275	24	276
132	B5	17	315	275	24	287
160	B5	17	600	560	12	330

*La dimensione M è in accordo al motore installato
 *h1: se h1 = 180, con motore taglia 160 diventa h1 = 190

XTS

Dimensioni d'ingombro

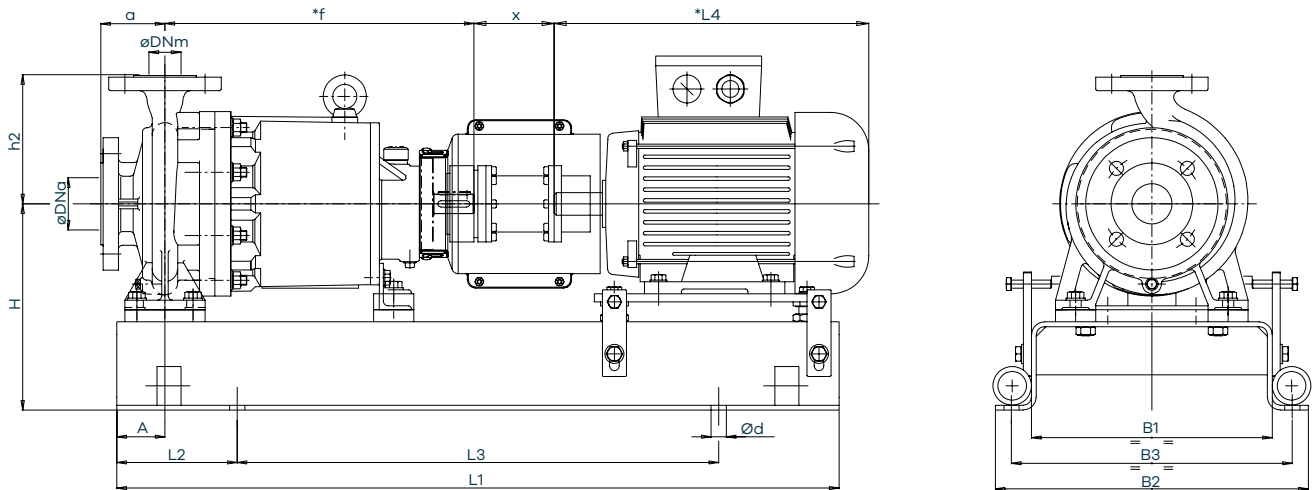

Dimensioni pompa

Modello	XTS 50-32-160	XTS 50-32-200	XTS 80-50-160	XTS 80-50-200
DNa	50	50	80	80
	UNI EN 1092-1 PN 16RF asolata ANSI 150			
DNm	32	32	50	50
	UNI EN 1092-1 PN 16RF asolata ANSI 150			
a (mm)	80	80	100	100
A (mm)	60	60	60	60
*f (mm)	385	385	385	385
h2 (mm)	160	180	180	200
x (mm)	100	100	100	100
H - dimensioni motore	80 (mm)	257	285	285
	90 (mm)	257	285	285
	100 (mm)	257	285	285
	112 (mm)	257	285	285
	132 (mm)	272	300	300
H 160 (mm)	272	300	300	300
Peso pompa (senza motore)	55	90	60	90

Dimensioni basamento

Dimensioni motore	B1 (mm)	B2 (mm)	B3 (mm)	ød (mm)	L1 (mm)	L2 (mm)	L3 (mm)	Peso basamento (senza motore)
80-90-100-112	300	390	350	M16	900	150	600	45
132	340	450	400	M20	1000	170	660	58
160	380	490	440	M20	1120	190	740	90

*La dimensione L4 è in accordo al motore installato

*f la lunghezza 385 diventa 400 con anello paraolio contactless