

XTN-BL

Dimensioni d'ingombro

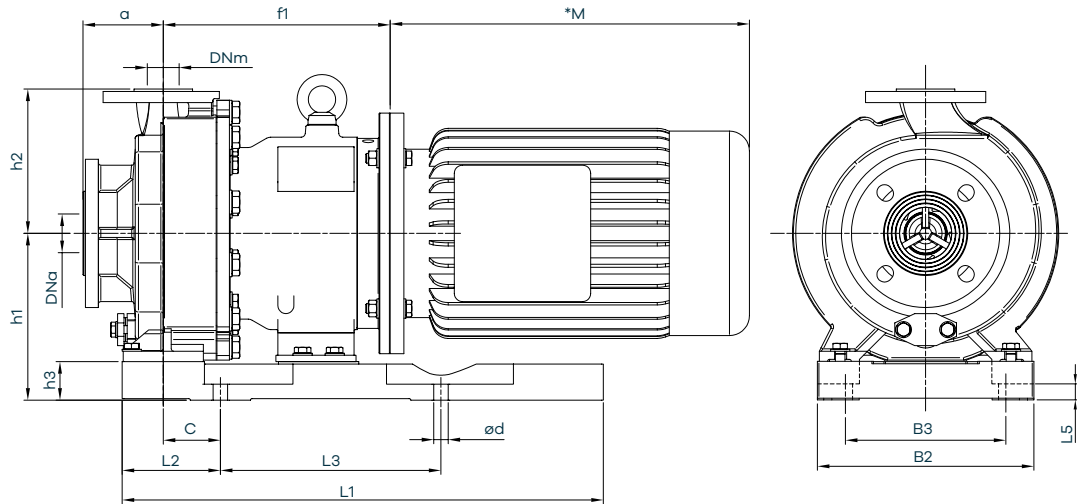

Dimensioni pompa

Modello	XTN-BL 50-32-160	XTN-BL 80-50-160	XTN-BL 80-50-200
DNa	50	80	80
	UNI EN 1092-1 PN 16RF asolata ANSI 150		
DNm	32	50	50
	UNI EN 1092-1 PN 16RF asolata ANSI 150		
a (mm)	80	100	100
h2 (mm)	160	180	200
h3 (mm)	48	48	48
L2 (mm)	550	550	550
L2 (mm)	122,5	122,5	122,5
L3 (mm)	275	275	275
L5 (mm)	20	20	20
B2 (mm)	270	270	270
B3 (mm)	200	200	200
c (mm)	70	70	70
ød (mm)	18	18	18

Dimensioni basamento

Dimensioni motore	XTN-BL 50-32-160	XTN-BL 80-50-160	XTN-BL 80-50-200
90 (mm)	257	257	257
100 (mm)	257	257	257
f1			
112 (mm)	257	257	257
132 (mm)	287	287	287
160 (mm)	302	302	302
h1			
90 (mm)	180	208	208
100 (mm)	180	208	208
112 (mm)	180	208	208
132 (mm)	180	208	208
160 (mm)	208	208	208
Forma motore	B5	B5	B5
Peso pompa (senza motore)	83	100	115

*La dimensione M è in accordo al motore installato